

Ihr sicherer Gewinn

Formgebung, Bauart

Platzsparend dank kompakter Bauart
Hundertprozentige Reproduzierbarkeit dank formschlüssigem Aufbau.

Hubeinstellung, Überwachung

Minimale Taktzeiten durch Einstellen der Abfragenocken über den gesamten Hubbereich und dadurch verzögerungsfreies Abfragen der Endstellungen
Hohe Verfügbarkeit, durch einfachen Ein- und Ausbau handelsüblicher Sensoren im Servicefall.

Kombinationsmöglichkeiten

Verschlauchungsaufwand entfällt in Verbindung mit Drehmodul DM
Minimaler Konstruktions- und Montageaufwand dank durchdachtem System und einheitlichem Rastermass.

Your definitive gain

Style, Design

Space-saving, thanks to compact design
One-hundred percent reproducibility thanks to positive interlocking design.

Stroke Setting, Monitoring

Minimum cycle times through the setting of the scanning cams over the entire stroke range, permitting non-retarded scanning of the end positions
High availability through simple removal and installation of commercial sensors in the event of service.

Combination Options

Piping work is not needed in combination with rotary module DM
Minimal construction and assembly work, thanks to well thought out system and uniform grid spacing.

Greifer pneumatisch | Grippers pneumatic

Technische Daten – Zusammenfassung | Technical Data – Summary

Parallelgreifer PG 4/5/6
Parallel Gripper PG 4/5/6

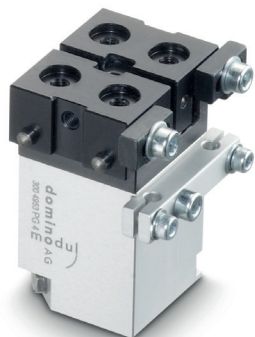

Winkelgreifer WG 4/5/6
Angle Gripper WG 4/5/6

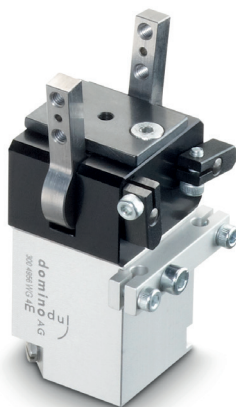

Parallelgreifer PG 402
Parallel Gripper PG 402



		PG 4	PG 5	PG 6	WG 4	WG 5	WG 6	PG 402	PG 502
Greifweise: Gripping mode:	parallel								
	winklig angular								
Zylinderdurchmesser [mm] Cylinder diameter [mm]:		10	16	25	10	16	25	12	12
Theor. Greifkraft öffnend bei 5 bar [N]: Theor. gripping force opening [N]:	Fo/Fb	19,5	50	122,5	39	180	245	41,7	41,7
Theor. Greifkraft schliessend bei 5 bar [N]: Theor. gripping force closing [N]:	Fs/Fa	16,5	46,5	110	33	93	220	41,7	41,7
Theor. Greifmoment öffnend [Ncm]: Theor. gripping moment opening [Ncm]:	Ma				8,25	34,8	110		
Theor. Greifmoment schliessend [Ncm]: Theor. gripping moment closing [Ncm]:	Mb				9,75	37,5	122,5		
Max. Länge Greiferbacken [mm]: Max. length of gripper jaws [mm]:	l	24	35	48	24	35	48	35	35
Greifhub je Seite [mm]: Gripping stroke per side [mm]:	h	3,0	4,5	6,0				5	5
Wirksame Hebellänge [mm]: Effective lever length [mm]:	s				5,00	7,5	10,00		
Achsabstand [mm]: Distance between axes [mm]:	a				21,00	31,50	42,00		
Greifwinkel [°]: Gripping angle [°]:	w				1,40	1,40	1,40		
Schwenkwinkel [°]: Swivel angle [°]:	v				91,40	91,40	91,40		
Luftverbrauch pro Zyklus bei 5 bar und Nennhub [NI]: Air consumption per cycle at 5 bar and nominal stroke [NI]:		0,01	0,03	0,11	0,01	0,03	0,11	0,02	0,02
Gewicht [kg]: Weight [kg]:		0,08	0,30	0,67	0,10	0,37	0,85	0,47	0,49
Wiederholgenauigkeit [mm]: Repeatability [mm]:		+/- 0,05	+/- 0,05	+/- 0,05	+/- 0,05	+/- 0,05	+/- 0,05	+/- 0,05	+/- 0,05
Massenträgheitsmoment [kg cm ²]: Mass moment of inertia [kg cm ²]:		0,067	0,67	2,19	0,067	0,67	2,19	2,29	2,38
Pneumatikanschluss: Pneumatic connection:		M5	M5	M5	M5	M5	M5	M5	M5

Greifer pneumatisch | Grippers pneumatic

Technische Daten | Technical Data

Parallelgreifer PG 4/5/6 | Parallel Gripper PG 4/5/6

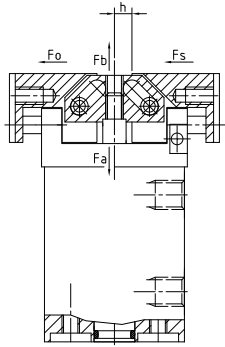

Winkelgreifer WG 4/5/6 | Angle Gripper WG 4/5/6

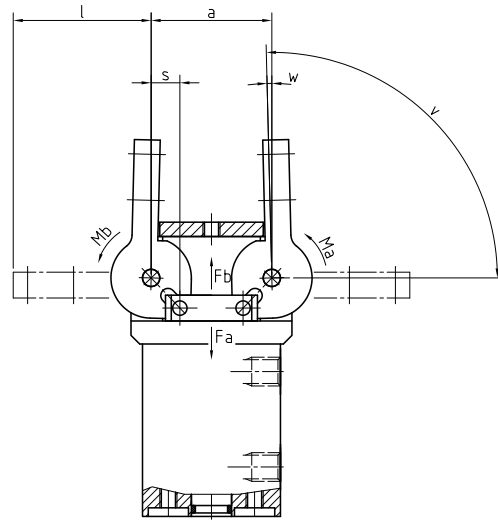

Parallelgreifer PG 402 A/502 A
Parallel Gripper PG 402 A/502 A

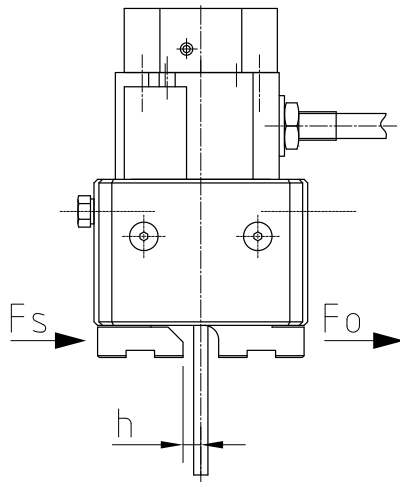

Parallelgreifer PG 502 A
Parallel Gripper PG 502 A



Beschreibung PG 502 A

- PG 502 A hat eine 30x30 Rasteradapterplatte mit direktem Luftdurchlass, so dass eine Pneumatikkupplung beim Einsatz eines Drehmoduls verwendet werden kann.
- Sowie einen AF 100 Abfragetaster (Teileanwesenheit) der bei der Endmontage mit den Greiferbacken gekürzt werden kann.

description PG 502 A

- PG 502A has a grid adapter plate 30x30 with a direct air lead-through that a pneumatic coupling can be used by the operation of a rotary module.
- As well as an AF 100 scanning switch-key (presence of a part) which can be shortened by the mounting of the gripper jaw.

Greifer pneumatisch | Grippers pneumatic

PG 402/502 – Parallelgreifer | PG 402/502 – Parallel Gripper

Massbild und Pneumatikschema | Dimensional drawing and pneumatic diagram

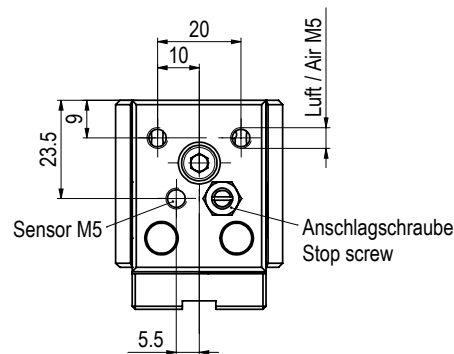
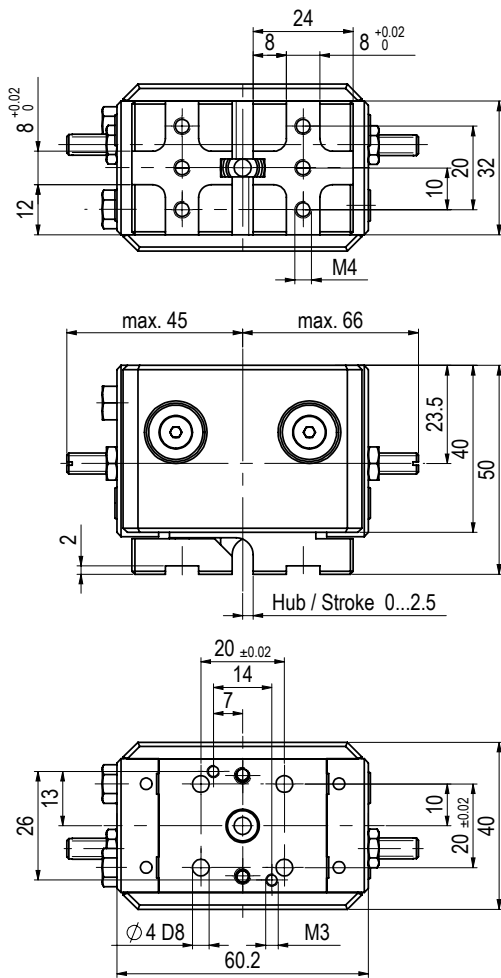

Verbindungsplatte connecting plate

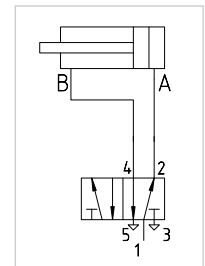
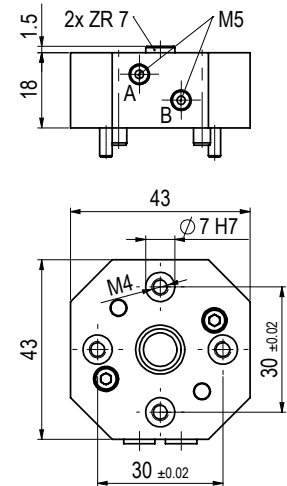

Bezeichnung	Designation	Bestellnr. Order no.
PG 402		300 3454
PG 502		300 5244
inkl. Verbindungsplatte und Zentrierringe $\varnothing 7$	incl. connecting plate and centering rings $\varnothing 7$	

Zubehör	Accessories	Bestellnr. Order no.
Zentrierring $\varnothing 7$	Centering ring $\varnothing 7$	300 1521
Endschalter M5x0,5	Limit switch M5x0.5	300 1866
Pneumatikkupplung PK5/6	Pneumatic coupling PK5/6	300 4985
Zentriercupplung ZK5/6	Centering coupling ZK5/6	300 2478
Schnellkupplungsset SKS 5	Fast-action coupling set SKS5	300 5221
Schnellkupplungsset SKS 6	Fast-action coupling set SKS6	300 5223