

Ihr sicherer Gewinn

Formgebung, Bauart

Platzsparend dank kompakter Bauart, klare geometrische Form, keine vorstehenden Kanten.
Einfacher Aufbau von Portalkombinationen dank frei wählbarer Länge des Grundprofils.
Hundertprozentige Reproduzierbarkeit dank formschlüssigem Aufbau.

Hubeinstellung, Überwachung

Flexibler Einsatz und hohe Wiederverwendbarkeit, da jeder beliebige Hub im Hubbereich einstellbar.
Einfaches und schnelles Einrichten dank Hubjustierung unter Druck, kein Nachjustieren der Sensoren. Hohe Verfügbarkeit durch einfachen Austausch handelsüblicher Sensoren im Servicefall.

Modular

Minimaler Konstruktions- und Montageaufwand dank durchdachtem System und einheitlichem Rastermass.

Your definitive gain

Style, Design

Space-saving, thanks to compact design, simple geometric form, no protruding edges.
Simple assembly of portal combinations, thanks to freely selectable length of the base profile.
One-hundred percent reproducibility, thanks to positive interlocking design.

Travel Adjustment, Monitoring

Flexible usage and high reusability, since every optional stroke within the range of travel can be set.
Simple and fast setup, thanks to travel adjustment under pressure, no readjustment of the sensors.
High availability due to easy exchange of commercial sensors in the event of service.

Modular

Minimal construction and assembly work required, thanks to well thought out system and uniform grid spacing.

Linearachsen | Linear Axes

Technische Daten – Zusammenfassung | Technical Data – Summary

			Pneumatische Achsen Pneumatic Axes				Elektrische Achsen Electrical Axes				
			LM 6 P	LM 8 P	LM 8 PV	LM 10 P	LM 6 PE	LM 8 PE	LM 8 PEV	LM 10 PE	
Standard Hublängen h [mm]: Standard stroke lengths h [mm]: Gesamtlänge [mm]: Overall length [mm]:	L	0-150	408	468	468	558	483	543	543	543	
		0-270	528	588	588	678	603	663	663	663	
		0-390	648	708	708	798	723	783	783	783	
		0-510	768	828	828	918	843	903	903	903	
		0-630	888	948	948	1038	963	1023	1023	1023	
		0-750	1008	1068	1068	1158	1083	1143	1143	1143	
		0-990				1398	1323	1383	1383	1383	
		0-1230				1638	1563	1623	1623	1623	
Hublänge max. [mm]: Stroke length max. [mm]:			3720	3660	3660	3570	3720	3660	3585	3585	
Gesamtlänge max. [mm]: Overall length max. [mm]:			3978	3978	3978	3978	4053	4053	4053	4053	
Zylinderdurchmesser [mm]: Cylinder diameter [mm]:			18	25	25	25					
Zwischenpositionen [-]: Intermediate positions [-]:											
Theor. Kraft Fa/Fb [N]: (bei 5bar)		126/126									
Theor. force Fa/Fb [N]: (at 5 bar)		245/245									
Theor. zulässige Kraft Fa/Fb [N]: Theor. permissible force Fa/Fb [N]:							540	900	900	900	
Maximale statische Momente [Nm]:		Ma	96	400	400	950	96	400	400	950	
Maximum static orques [Nm]:		Mb	96	400	400	950	96	400	400	950	
		Mc	64	192	560	480	64	192	560	480	
Wiederholgenauigkeit [mm]: Repeat accuracy [mm]:			+/- 0,02	+/- 0,02	+/- 0,02	+/- 0,02	+/- 0,1	+/- 0,1	+/- 0,1	+/- 0,1	
Max. zulässige Masse [kg]: Max. permissible mass [kg]:			4	8	16	16	4	8	16	16	
Gewicht [kg]: Torques [kg]:			0-150	4,1	7,6	9,8	11,0	4,1	8,2	10,2	12,5
			0-270	5,0	9,4	12,1	13,0	4,7	9,7	12,1	13,3
			0-390	5,9	11,2	14,3	15,0	5,4	11,2	14,1	15,0
			0-510	6,8	13,0	16,6	17,0	6,0	12,7	16,1	16,7
			0-630	7,7	14,8	18,8	19,0	6,6	14,2	18,1	18,4
			0-750	8,7	16,6	21,1	21,0	7,3	15,7	20,0	20,1
			0-990	9,8	18,2	23,7	25,0	8,5	18,7	24,0	23,6
			0-1230	11,4	19,8	25,3	29,0	9,8	21,7	28,0	27,0
Luftverbrauch pro Zyklus bei 5bar und Nennhub [NI]: Air consumption per cycle at 5 bar and nominal stroke [NI]:			0-150	0,45	0,80	0,80	0,80				
			0-270	0,78	1,45	1,45	1,45				
			0-390	1,12	2,10	2,10	2,10				
			0-510	1,46	2,75	2,75	2,75				
			0-630	1,79	3,40	3,40	3,40				
			0-750	2,13	4,05	4,05	4,05				
			0-990				5,35				
			0-1230				6,65				
Pneumatikanschlüsse: Pneumatic connections:			G1/8"	G1/8"	G1/8"	G1/8"					

Linearachsen | Linear Axes

Technische Daten – Belastungsdiagramme | Technical Data – Load Diagrams

Längsbelastung | Axial Load

Die Grafik zeigt die Auslenkung f des Schlittens im Punkt A (Hebelarm 100 mm) unter Einwirkung des Momentes M_a .

The graph shows the deflection f of the slide at point A (lever arm 100 mm) under the effect of the torque M_a .

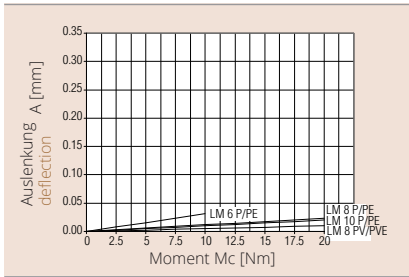
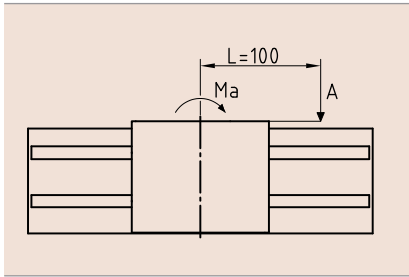

Querbelastung | Transverse Load

Die Grafik zeigt die Auslenkung f des Schlittens im Punkt A (Hebelarm 100 mm) unter Einwirkung des Momentes M_b .

The graph shows the deflection f of the slide at point A (lever arm 100 mm) under the effect of the torque M_b .

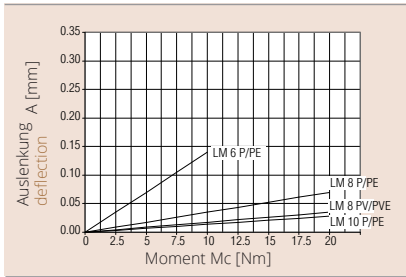
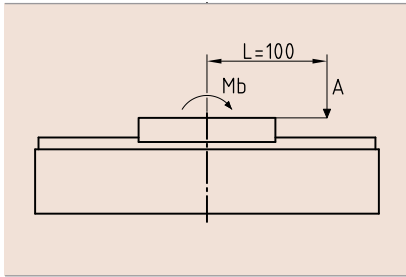

Seitenbelastung | Lateral Load

Die Grafik zeigt die Auslenkung f des Schlittens im Punkt A (Hebelarm 100 mm) unter Einwirkung des Momentes M_c .

The graph shows the deflection f of the slide at point A (lever arm 100 mm) under the effect of the torque M_c .

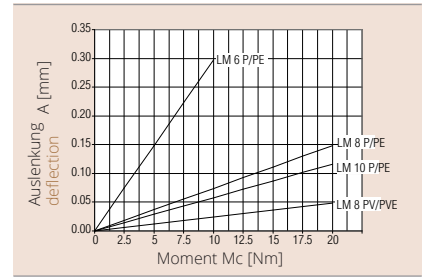
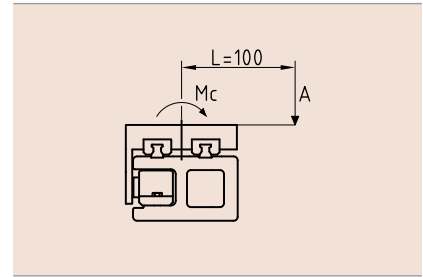

Biegekennlinien | Bending characteristics

Das Diagramm zeigt die Durchbiegung des Aluminiumprofils, Lastfall statisch

The diagram shows the sagging of the aluminium profile, static loading

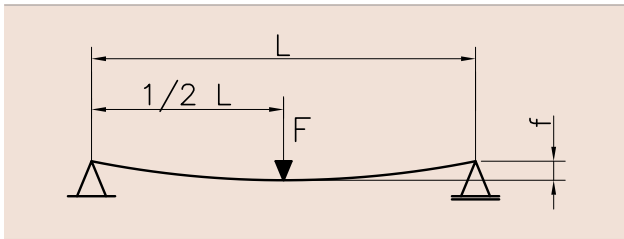

Momente Achse Torques Axis

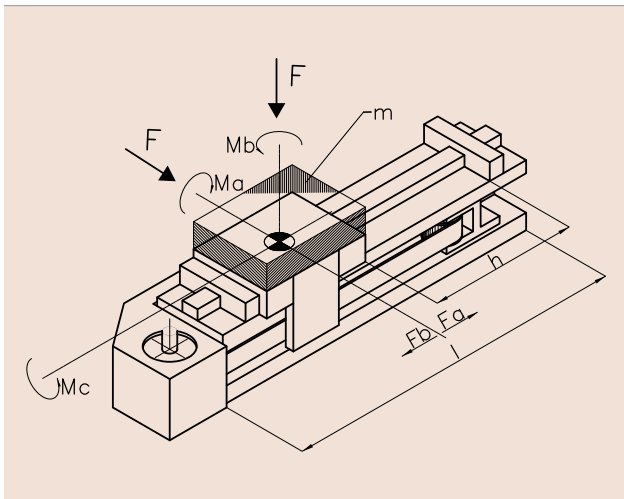

LM 6 P / LM 6 PE

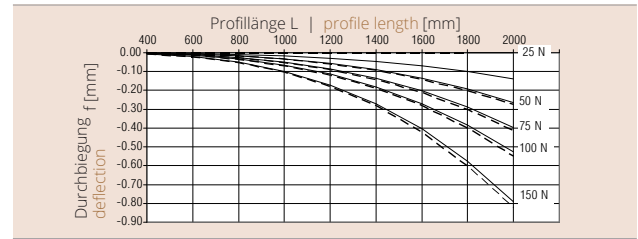

LM 8 P / LM 8 PV / LM 8 PE / LM 8 PEV

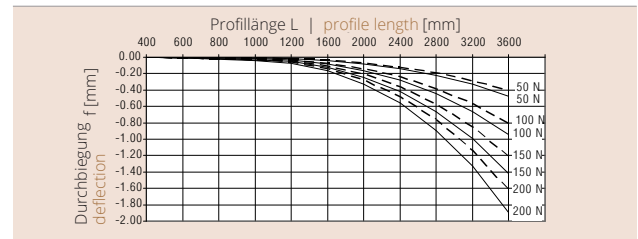

LM 10 P / LM 10 PE

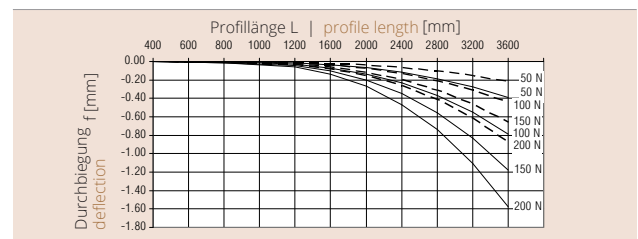

LM 8 PE

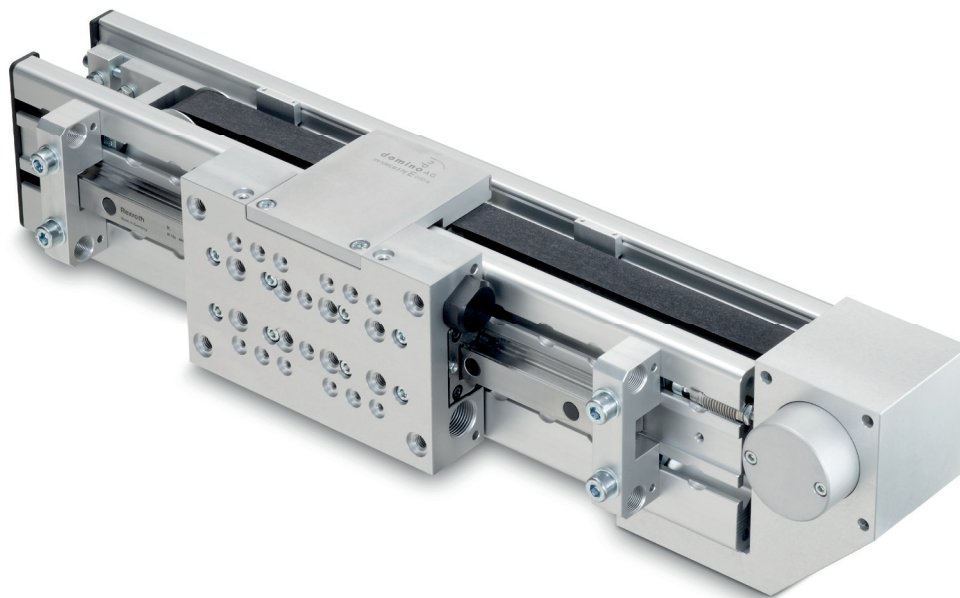

Technische Daten, hubunabhängig		Technical data, stroke-independent	
Antriebsraddurchmesser		Drive wheel diameter	38,2 mm
Zähnezahl Antriebsrad		Number of teeth, drive wheel	24
Zahnteilung		Tooth pitch	5 mm
Hub bei 1 Umdrehung des Antriebsrades		Stroke at 1 drive wheel rotation	120 mm
theor. Kraft bei 1 Nm Fa/Fb		Theor. force at 1 Nm Fa/Fb	52 N
theor. zulässige Kraft Fa/Fb		Theor. permissible force Fa/Fb	900 N
max. Geschwindigkeit		Max. speed	3 m/s
max. Beschleunigung/Verzögerung		Max. acceleration/deceleration	7,5 m/s ²
Antriebsdrehmoment		Driving torque	0 bis 17 Nm
Translatorisch bewegte Grundmasse (Schlitten, Lager, Zahnriemen etc.)		Basic mass moved through linear motion (slide, bearing, toothed belt etc.)	
Antriebsrad:	Durchmesser x Breite Gewicht Material Stahl	Drive wheel:	diameter x width weight material Steel
			Ø 39 mm x 31 mm 0,350 kg
Umlenkrad:	Durchmesser x Breite Gewicht inkl. Lager Material Aluminium	Guide wheel:	diameter x width weight incl. bearing material Aluminium
			Ø 39 mm x 31 mm 0,050 kg
Reibmoment		Frictional torque	0,25 Nm
Temperaturbereich		Temperature range	0 - 60°C
Wiederholgenauigkeit		Repeat accuracy	+/-0.1 mm
max. zulässige Masse		Max. permissible mass	m 8 kg
max. statische Momente		Max. static torques	Ma 400 Nm Mb 400 Nm Mc 192 Nm
Technische Daten, hubabhängig		Technical data, stroke-dependent	
Siehe Seite 10		See page 10	

Linearachsen | Linear Axes

LM 8 PE – elektrische Linearachse | LM 8 PE – Electrical Linear Axis

Massbild LM 8 PE | Dimensional drawing LM 8 PE

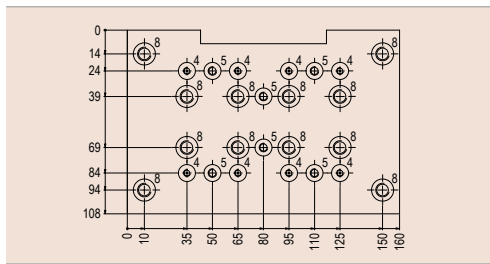
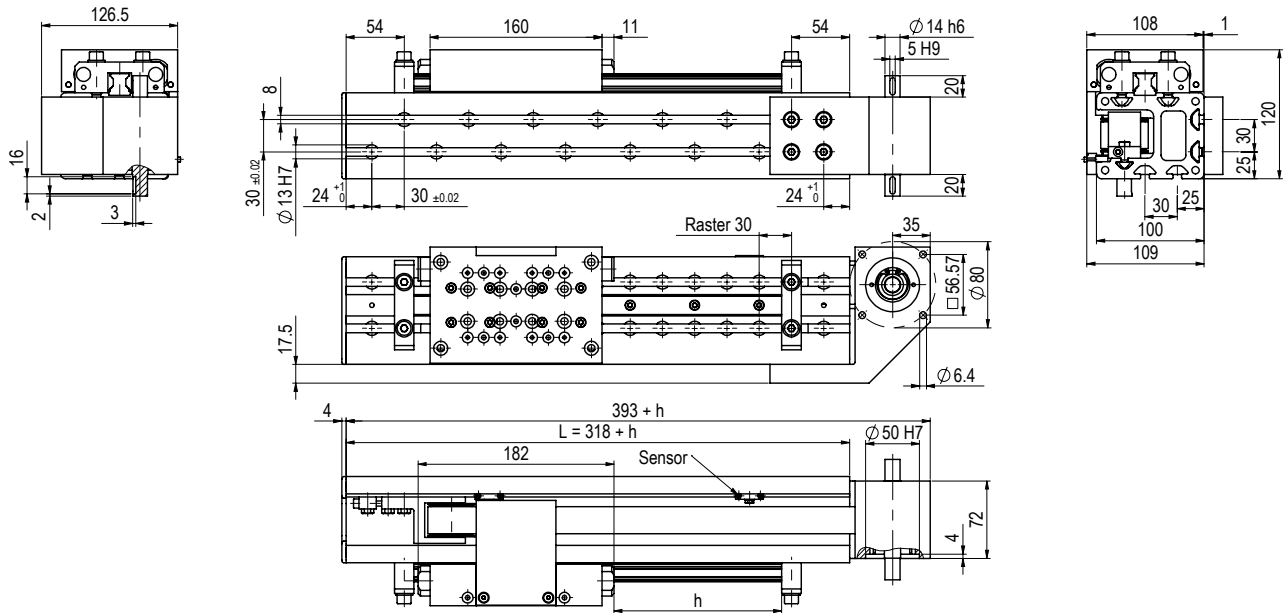

Nr. Zentrierung No. Centering	Gewinde Thread
4 Ø10H7 / 2.1 tief deep	M4
5 Ø10H7 / 2.1 tief deep	M5
8 Ø13H7 / 2.1 tief deep	M8

Lochdistanz +/-0.02 mm
Hole distance +/-0.02 mm

Bezeichnung	Designation	Bestellnr. Order no.
LM 8 PE-150 li	links left	300 5091
LM 8 PE-270 li		300 5092
LM 8 PE-390 li		300 5093
LM 8 PE-510 li		300 5094
LM 8 PE-630 li		300 5095
LM 8 PE-750 li		300 5096
LM 8 PE-990 li		300 5097
LM 8 PE-1230 li		300 5098
LM 8 PE-150 re	rechts right	300 5099
LM 8 PE-270 re		300 5100
LM 8 PE-390 re		300 5101
LM 8 PE-510 re		300 5102
LM 8 PE-630 re		300 5103
LM 8 PE-750 re		300 5104
LM 8 PE-990 re		300 5105
LM 8 PE-1230 re		300 5106
Sonderlänge bis 3660 mm	Custom length up to 3660 mm	
inkl. 1 Abdeckkappe, 4 Zentrierringe Ø 13 und 4 Zentrierringe Ø 10	Incl. 1 cover caps, 4 centering rings Ø13 and 4 centering rings Ø10	

Zubehör Accessories		
Zentrierring Ø 10	Centering ring Ø 10	300 1522
Zentrierring Ø 13	Centering ring Ø 13	300 1523
Endschalter 8 x 8	Limit switch 8 x 8	301 5214
Flansche, Kupplungen siehe Seite 28	Flange, shaft coupling, see page 28	
Energieführungsketten siehe Seite 29	Energy management chains, see page 29	