

Ihr sicherer Gewinn

Formgebung, Bauart

Platzsparend dank kompakter Bauart, klare geometrische Form, keine vorstehenden Kanten.
Einfacher Aufbau von Portalkombinationen dank frei wählbarer Länge des Grundprofils.
Hundertprozentige Reproduzierbarkeit dank formschlüssigem Aufbau.

Hubeinstellung, Überwachung

Flexibler Einsatz und hohe Wiederverwendbarkeit, da jeder beliebige Hub im Hubbereich einstellbar.
Einfaches und schnelles Einrichten dank Hubjustierung unter Druck, kein Nachjustieren der Sensoren. Hohe Verfügbarkeit durch einfachen Austausch handelsüblicher Sensoren im Servicefall.

Modular

Minimaler Konstruktions- und Montageaufwand dank durchdachtem System und einheitlichem Rastermass.

Your definitive gain

Style, Design

Space-saving, thanks to compact design, simple geometric form, no protruding edges.
Simple assembly of portal combinations, thanks to freely selectable length of the base profile.
One-hundred percent reproducibility, thanks to positive interlocking design.

Travel Adjustment, Monitoring

Flexible usage and high reusability, since every optional stroke within the range of travel can be set.
Simple and fast setup, thanks to travel adjustment under pressure, no readjustment of the sensors.
High availability due to easy exchange of commercial sensors in the event of service.

Modular

Minimal construction and assembly work required, thanks to well thought out system and uniform grid spacing.

Linearachsen | Linear Axes

Technische Daten – Zusammenfassung | Technical Data – Summary

			Pneumatische Achsen Pneumatic Axes				Elektrische Achsen Electrical Axes			
			LM 6 P	LM 8 P	LM 8 PV	LM 10 P	LM 6 PE	LM 8 PE	LM 8 PEV	LM 10 PE
Standard Hublängen h [mm]: Standard stroke lengths h [mm]: Gesamtlänge [mm]: Overall length [mm]:	L	0-150	408	468	468	558	483	543	543	543
		0-270	528	588	588	678	603	663	663	663
		0-390	648	708	708	798	723	783	783	783
		0-510	768	828	828	918	843	903	903	903
		0-630	888	948	948	1038	963	1023	1023	1023
		0-750	1008	1068	1068	1158	1083	1143	1143	1143
		0-990				1398	1323	1383	1383	1383
		0-1230				1638	1563	1623	1623	1623
Hublänge max. [mm]: Stroke length max. [mm]:			3720	3660	3660	3570	3720	3660	3585	3585
Gesamtlänge max. [mm]: Overall length max. [mm]:			3978	3978	3978	3978	4053	4053	4053	4053
Zylinderdurchmesser [mm]: Cylinder diameter [mm]:			18	25	25	25				
Zwischenpositionen [-]: Intermediate positions [-]:										
Theor. Kraft Fa/Fb [N]: (bei 5bar) Theor. force Fa/Fb [N]: (at 5 bar)		126/126 245/245								
Theor. zulässige Kraft Fa/Fb [N]: Theor. permissible force Fa/Fb [N]:							540	900	900	900
Maximale statische Momente [Nm]: Maximum static orques [Nm]:		Ma Mb Mc	96 96 64	400 400 192	400 400 560	950 950 480	96 96 64	400 400 192	400 400 560	950 950 480
Wiederholgenauigkeit [mm]: Repeat accuracy [mm]:			+/- 0,02	+/- 0,02	+/- 0,02	+/- 0,02	+/- 0,1	+/- 0,1	+/- 0,1	+/- 0,1
Max. zulässige Masse [kg]: Max. permissible mass [kg]:			4	8	16	16	4	8	16	16
Gewicht [kg]: Torques [kg]:		0-150 0-270 0-390 0-510 0-630 0-750 0-990 0-1230	4,1 5,0 5,9 6,8 7,7 8,7 9,8 11,4	7,6 9,4 11,2 13,0 14,8 16,6 18,2 19,8	9,8 12,1 14,3 16,6 18,8 21,1 23,7 25,3	11,0 13,0 15,0 17,0 19,0 21,0 25,0 29,0	4,1 4,7 5,4 6,0 6,6 7,3 8,5 9,8	8,2 9,7 11,2 12,7 14,2 15,7 18,7 21,7	10,2 12,1 14,1 16,1 18,1 20,0 24,0 28,0	12,5 13,3 15,0 16,7 18,4 20,1 23,6 27,0
Luftverbrauch pro Zyklus bei 5bar und Nennhub [NI]: Air consumption per cycle at 5 bar and nominal stroke [NI]:		0-150 0-270 0-390 0-510 0-630 0-750 0-990 0-1230	0,45 0,78 1,12 1,46 1,79 2,13	0,80 1,45 2,10 2,75 3,40 4,05	0,80 1,45 2,10 2,75 3,40 4,05	0,80 1,45 2,10 2,75 3,40 4,05				
Pneumatikanschlüsse: Pneumatic connections:			G1/8"	G1/8"	G1/8"	G1/8"				

Linearachsen | Linear Axes

Technische Daten – Belastungsdiagramme | Technical Data – Load Diagrams

Längsbelastung | Axial Load

Die Grafik zeigt die Auslenkung f des Schlittens im Punkt A (Hebelarm 100 mm) unter Einwirkung des Momentes M_a .

The graph shows the deflection f of the slide at point A (lever arm 100 mm) under the effect of the torque M_a .

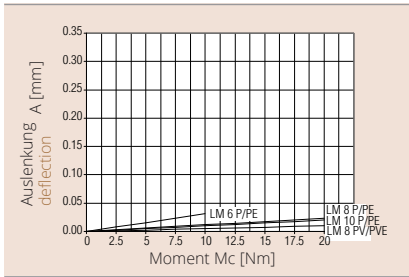
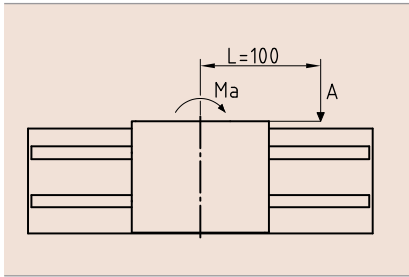

Querbelastung | Transverse Load

Die Grafik zeigt die Auslenkung f des Schlittens im Punkt A (Hebelarm 100 mm) unter Einwirkung des Momentes M_b .

The graph shows the deflection f of the slide at point A (lever arm 100 mm) under the effect of the torque M_b .

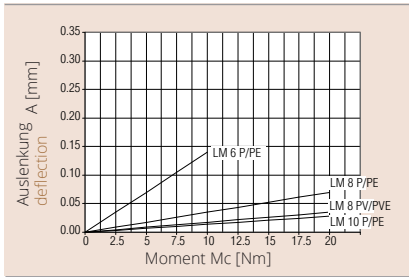
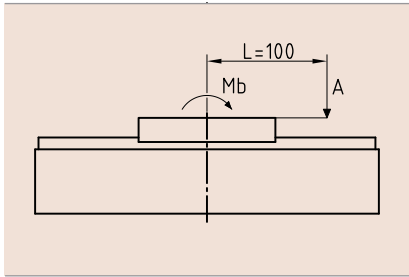

Seitenbelastung | Lateral Load

Die Grafik zeigt die Auslenkung f des Schlittens im Punkt A (Hebelarm 100 mm) unter Einwirkung des Momentes M_c .

The graph shows the deflection f of the slide at point A (lever arm 100 mm) under the effect of the torque M_c .

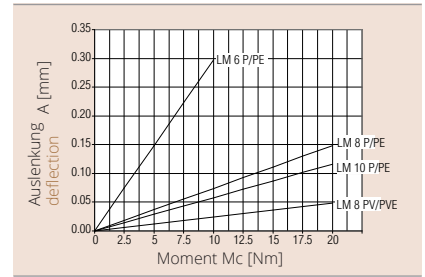
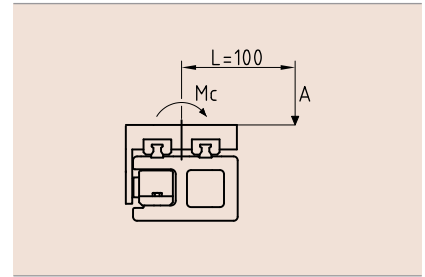

Biegekennlinien | Bending characteristics

Das Diagramm zeigt die Durchbiegung des Aluminiumprofils, Lastfall statisch

The diagram shows the sagging of the aluminium profile, static loading

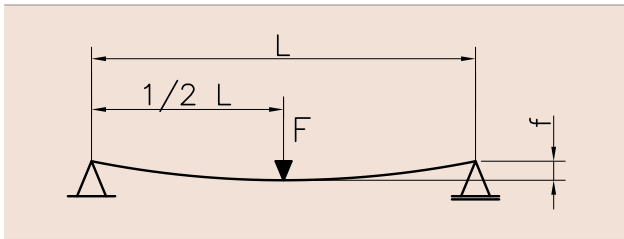

Momente Achse
Torques Axis

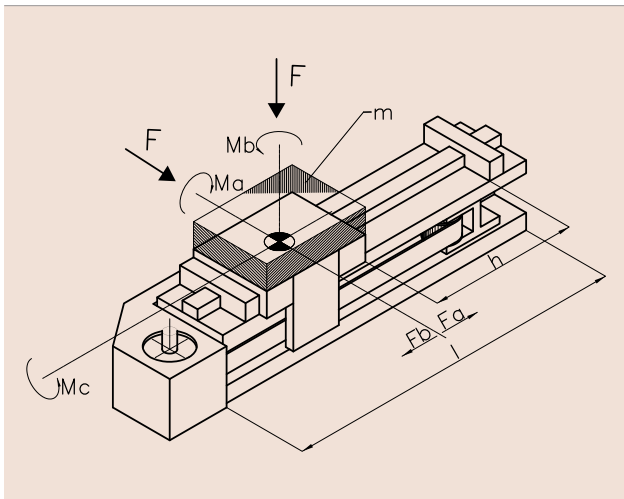

LM 6 P / LM 6 PE

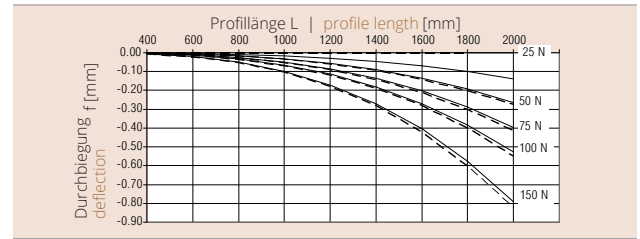

LM 8 P / LM 8 PV / LM 8 PE / LM 8 PEV

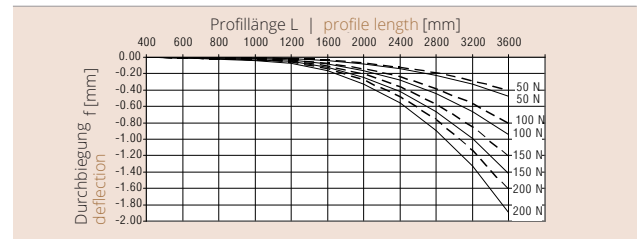

LM 10 P / LM 10 PE

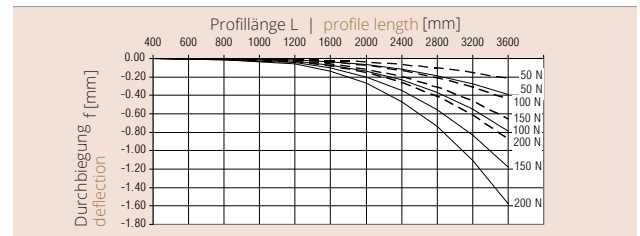

LM 6 P

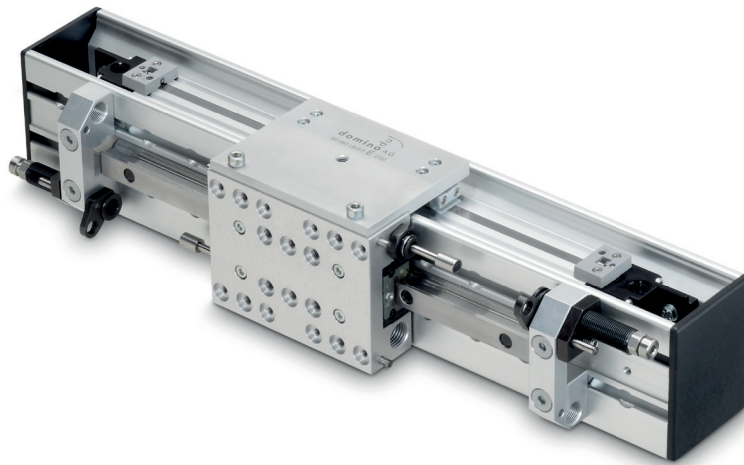

Technische Daten, hubunabhängig | Technical data, stroke-independent

Zylinderdurchmesser	Cylinder diameter	18 mm
theor. Kraft (bei 5 bar) Fa/Fb	Theor. force (at 5 bar) Fa/Fb	126 N/126 N
max. Geschwindigkeit	Max. speed	1,2 m/s
Medium Druckluft	Medium Compressed-air	trocken gefiltert dry filtered
Betriebsdruckbereich	Operating pressure range	3 – 7 bar
Temperaturbereich	Temperature range	0 – 60°C
Wiederholgenauigkeit	Repeat accuracy	+/-0.02 mm
max. zulässige Masse	Max. permissible mass	4 kg
max. statische Momente	Max. static torques	Ma 96 Nm Mb 96 Nm Mc 64 Nm

Technische Daten, hubabhängig | Technical data, stroke-dependent

Siehe Seite 10 | See page 10

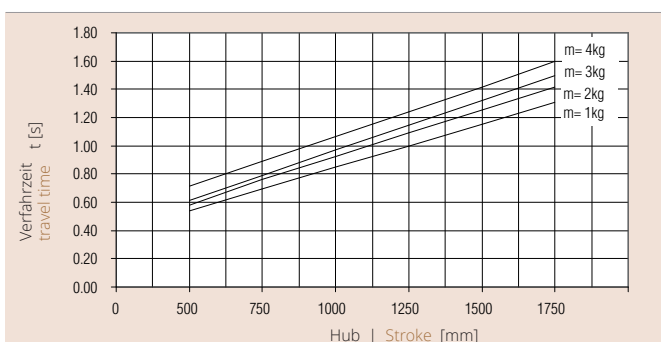
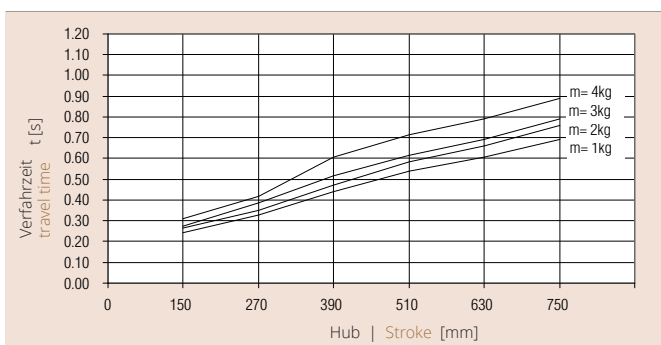

Zulässige Verfahzeit t in Abhängigkeit der Hublänge und der Zusatzmasse m

Die aus dem Diagramm ermittelte Verfahzeit t darf nicht unterschritten werden, diese ist ohne Ventilschaltzeit bei Nenn- druck 6 bar gemessen. Empfehlung: Bei Auslegung der Achse sollte die Verfahzeit t um 20% erhöht angenommen werden.

Permissible travel time t relative to the stroke length and the additional mass m

The travel time t determined from the diagram may not be exceeded this is measured without valve switching time at nominal pressure 6 bar. Recommendation: During the design of the axis, the travel time t should be assumed to be about 20% more.

Linearachsen | Linear Axes

LM 6 P – pneumatische Linearachse | LM 6 P – Pneumatic Linear Axis

Massbild und Pneumatikschema | Dimensional drawing and pneumatic diagram

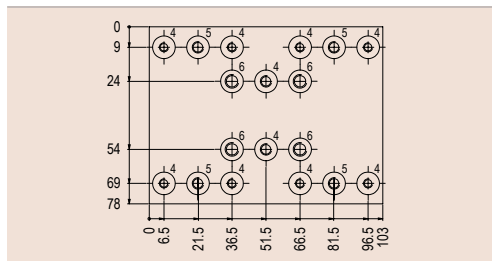
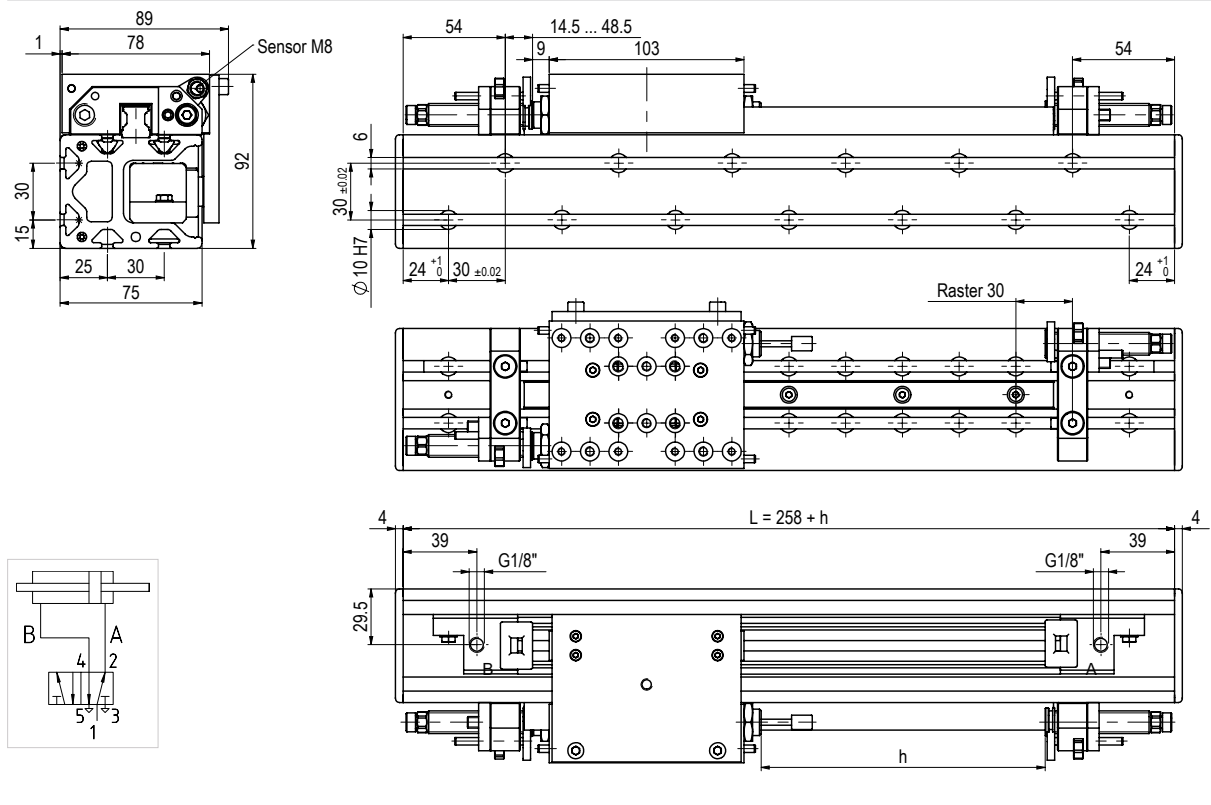

Bezeichnung	Designation	Bestellnr.	Order no.
LM 6 P-150		300 4962	
LM 6 P-270		300 4963	
LM 6 P-390		300 4964	
LM 6 P-510		300 4965	
LM 6 P-630		300 4966	
LM 6 P-750		300 4967	
Sonderlänge bis 3720 mm	Custom length up to 3720 mm		
inkl. 2 hydr. Stossdämpfer, 4 Zentrierringe Ø 10 und 2 Abdeckkappen	Incl. 2 hydr. shock absorbers, 4 centering rings Ø10 and 2 cover caps		
Zubehör	Accessories		
Zentrierring Ø 10	Centering ring Ø 10	300 1522	
Endschalter M8x1	Limit switch M8x1	300 3174	
Stossdämpfer	Shock absorber	300 1387	
Energieführungsketten siehe Seite 29	Energy management chains, see page 29		
Zwischenanschlag siehe Seite 30	Intermediate stop, see page 30		